



## T125 / T125ID USER MANUAL

T125 (ID) is a tiny temperature sensor that supports multiple telemetry protocols. It can be used to measure temperature of the electric motor, batteries and other aspects of your model.

The T125ID is able to communicate with the IBEX controllers as it offers direct temperature readings of the motor temperature to the controller. It also contains some memory space for predefined motor parameters. In case you don't want to play with the IBEX ESC settings, use the T125ID sensor to store the motor parameters. As a result, the controller will read the motor settings and adjust its own behavior.

### FEATURES

- Small dimensions. The sensor is connected directly to the receiver telemetry port.
- Temperature min/max values are logged.
- Automatic telemetry detection: Duplex EX, Hott, MSB, S.Bus2, P<sup>2</sup>Bus.
- Configurable alarms on high temperature.
- Configuration through the transmitter or MAV Manager PC software.
- Firmware updates.
- T125ID: Communication with the IBEX controllers.

	T125
<b>Dimensions</b>	21,5x10x4mm
<b>Weight</b>	1g
<b>Temperature range</b>	-10÷125°C
<b>Temperature resolution</b>	1°C
<b>Operating current</b>	4mA
<b>Supply Voltage</b>	3.5 - 12V
<b>Telemetry</b>	Duplex EX, Multiplex MSB, Graupner Hott, Futaba S.Bus2, PowerBox P <sup>2</sup> Bus
<b>Status LED</b>	NO

**Installation**  
Connect the T125 directly to the receiver telemetry port as shown in the picture.

**JETIBOX Connection**  
Plug the T125 into the sensor slot of the JETIBOX. Power it up with a battery (4.5 - 8.4V). Now you can configure the sensor using the arrows on the JETIBOX.

**IBEX controller connection**  
Connect the T125ID sensor to the controller using the supplied JR/Micro-JST cable adapter. Use the "IN A" port on the controller.

# TELEMETRY AND SETTINGS

## JETIBOX Menu Structure

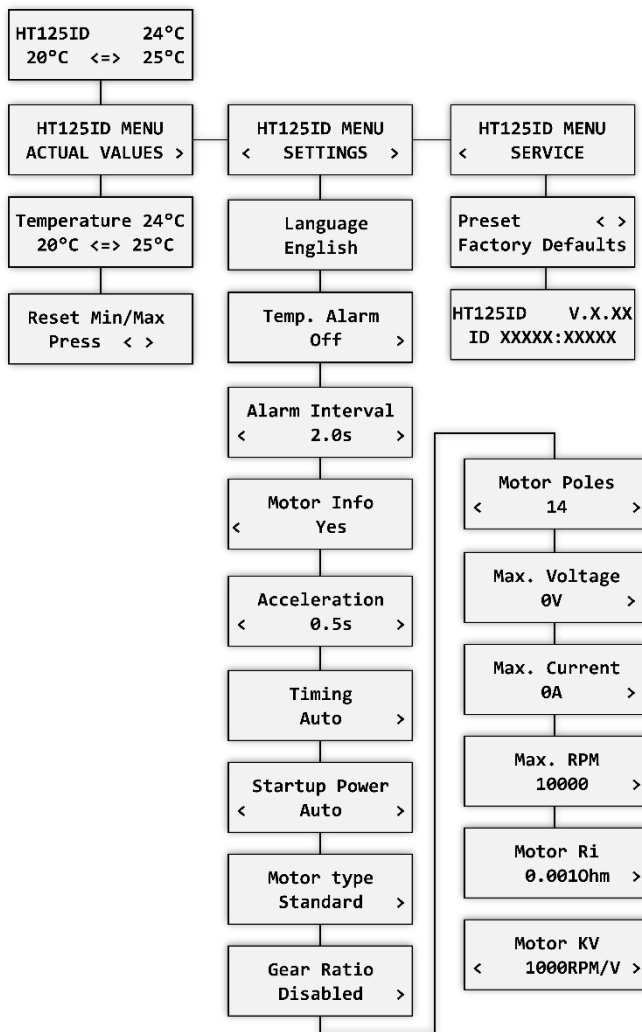

The device is compatible with JETIBOX for programming. The JETIBOX menu is divided into three sections:

- **Actual values** – displays the latest telemetry values together with minimums and maximums.
  - Reset Min/Max - press left+right buttons together to reset all minimums and maximums.
- **Settings** – basic settings of the sensor
  - **Language** – you can choose the language of the JETIBOX screen.
  - **Temperature Alarm** – you can set a high temperature alarm. \*)
  - **Alarm Interval** – sets the time period between alarm announcement.
- **Motor Info** – settings related to motor identification (T125ID only). If you enable this option, the configured motor parameters will be available to the IBEX controller.
  - **Acceleration** – sets the fastest possible acceleration, still safe for the motor.
  - **Timing** – either automatically detected by the ESC, or manual (0°-30°).
  - **Startup Power** – power used to start the motor spinning.
  - **Motor type** – standard / high torque / high RPM.
- **Service** – In this menu you can view the device version and reset it to the default factory configuration.

\*) The alarm setting is compatible with Duplex and Hott systems.

## Graupner Hott Menu Structure

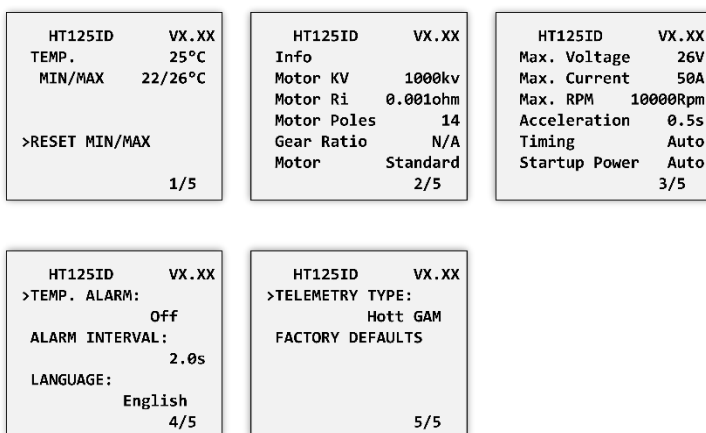

The T125 is recognized by default as a General Air Module. This can be changed to “EAM” or “Air-ESC” mode through the menu.

## Futaba and Multiplex connection

Futaba and Multiplex systems do not offer wireless device configuration. The telemetry transmission is possible with the following fixed sensor slots:

	Futaba S.Bus2	Multiplex MSB
<b>Temperature</b>	1	5
<b>Note</b>	Manual detection in the menu Linkage – Sensor. Choose T125 on slot 1.	Automatically detected by the transmitter.

## FIRMWARE UPDATE

Firmware updates for the T125(ID) are transferred from a PC via the USB interface. The required programs and files are available at [www.mavsense.com](http://www.mavsense.com).

Install the MAV Manager software and the USB drivers on your computer. Check the system requirements.

- 1) Connect the USB interface to your PC, run MAV Manager and select the correct COM Port.
- 2) Connect the T125(ID) according to the picture below.
- 3) Select the correct \*.BIN file and press the Update button.

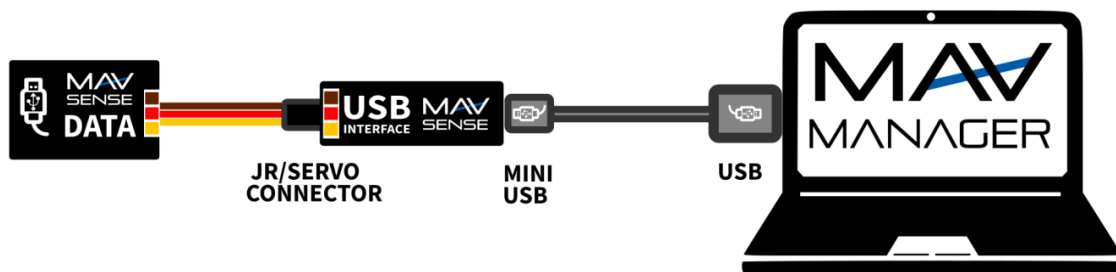

## PC CONFIGURATION

It is possible to use the MAV Manager software (1.6.0 and later) to conveniently configure all device settings, display real-time telemetry and make a configuration backup. The configuration menu contains four buttons in the top toolbar:

- **Refresh** – forces the configuration to be reloaded from the device.
- **Import** – imports the settings from a file. If you have several devices and want identical settings for all of them, simply import the same settings to each device.
- **Export** – exports the settings from the device to a file. You can easily create a backup configuration stored in your PC. After creating a backup, you may easily experiment with the settings and later revert back to the original configuration by pressing the “Import” button and choosing the original exported file.
- **Reset default** – resets the device to factory defaults and reloads all the settings.

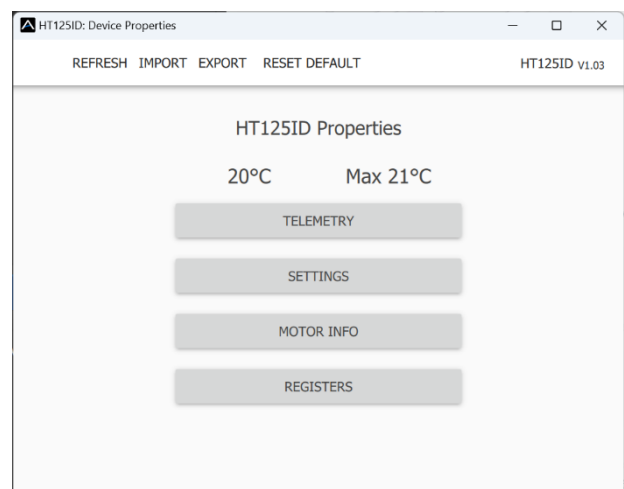
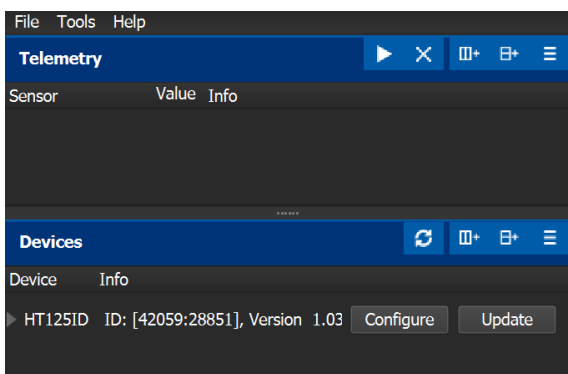

Connect the T125(ID) to your PC using the USB interface. The device will be automatically detected by the MAV Manager. The device properties are available after pressing the “Configure” button.

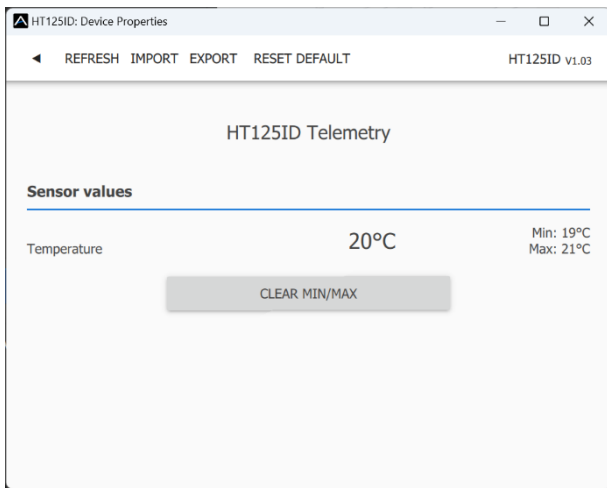

Real-time telemetry with min/max values. The MAV Manager is also able to create a log file from the real-time telemetry data, which can be viewed, analyzed, imported and exported.

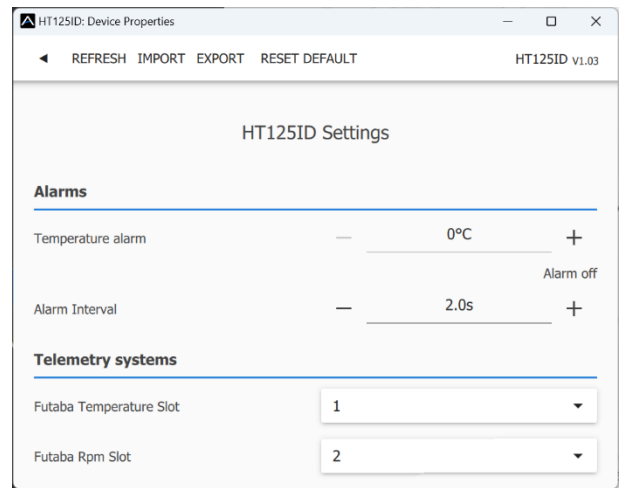

T125(ID) settings. Every time you make any change in the configuration, the new value is immediately transferred to the device and saved to memory. There is no need for additional confirmation.

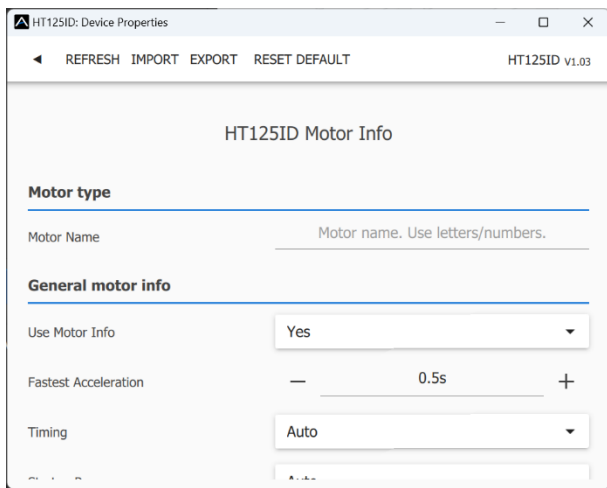

Motor information screen. The settings configured in this menu will be read and used by the IBEX controllers.

## SAFETY INFORMATION

- Operate the T125 always in dry environment and within the device limits stated in this guide. Never expose the device to excessive heat or cold.
- Do not remove the heat shrink tube from the device and do not try to implement any changes or modifications. This can lead to a total destruction and to the denial of any warranty claims.
- Always check the polarity of the connection. Never inverse the polarity – this could lead to total destruction.

## WARRANTY

We grant a warranty of 24 months from the day of purchase under the assumption that they have been operated in conformity with these instructions at recommended voltages and that they were not damaged mechanically. Warranty and post warranty service is provided by the manufacturer.



## Distributor

**GB: ESG-JETI-FIALA UK**, B M Jones, 15 London Road, Hassocks, West Sussex, BN6 9NT, United Kingdom.

E-mail: [sales@esoaringgadgets.co.uk](mailto:sales@esoaringgadgets.co.uk) | Website: [www.esoaringgadgets.co.uk](http://www.esoaringgadgets.co.uk) | Phone: 44(0)7740181861

## Manufacturer

**MAV Sense s.r.o.**, Czech Republic.

E-mail: [info@mavsense.com](mailto:info@mavsense.com) | Website: [www.mavsense.com](http://www.mavsense.com)

## Information on Disposal for Users of Waste Electrical & Electronic Equipment (private households)

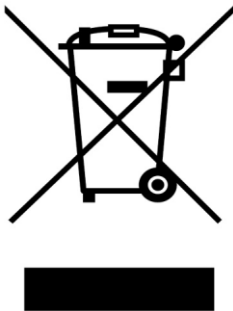

This symbol on the products and/or accompanying documents means that used electrical and electronic products should not be mixed with general household waste.

For proper treatment, recovery and recycling, please take these products to designated collection points, where they will be accepted on a free of charge basis.

Alternatively, in some countries you may be able to return your products to your local retailer upon the purchase of an equivalent new product.

Disposing of this product correctly will help to save valuable resources and prevent any potential negative effects on human health and the environment which could otherwise arise from inappropriate waste handling.

Please contact your local authority for further details of your nearest designated collection point.

Penalties may be applicable for incorrect disposal of this waste, in accordance with national legislation.

### **For business users in the European Union**

If you wish to discard electrical and electronic equipment, please contact your dealer or supplier for further information.

### **Information on Disposal in other Countries outside the European Union**

This symbol is only valid in the European Union.

If you wish to discard this product, please contact your local authorities or dealer and ask for the correct method of disposal.